

# Client Guide for the Inspection of Steel Chimneys



This guide is issued by ATLAS to give a general guidance of 'good practice'. ATLAS and the organisations responsible for its content do not accept any liability arising in any way from relying on this guide. If you require guidance on a specific issue, you should seek your own independent advice.

© ATLAS Ltd 2017 all rights reserved

Requests to use any part of this guide, unless noted as being freely available from the ATLAS website

[www.atlas.org.uk](http://www.atlas.org.uk), should be made in writing to:

Association of Technical Lightning & Access Specialists (ATLAS)

6-8 Bonhill Street

London

EC2A 4BX.

## **Acknowledgements**

This Guide has been produced with the help of:

Beaumont Specialist Contracting Ltd

ATLAS Safety & Access Committee

HSE (Health & Safety Executive)

CICIND (International Committee on Industrial Construction).

The ATLAS Safety & Access Committee would like to thank the following for their professional guidance and considerable input in the preparation of this document, in particular Mr Michael Beaumont (Beaumont Specialist Contracting Ltd), Mr John Turner (John Turner (Engineering Consultants) Ltd), Mr David Hughes (Proteq Ltd) and Mr Wayne Murry (Churchill Specialist Contracting Ltd and Chairman of the ATLAS Safety & Access Committee).

## Table of contents

Foreword.....	3
Preface.....	4
Introduction.....	5
Why Inspect a Chimney? .....	5
The Law.....	5
Guidance Document.....	6
The Client.....	6
The Contractor .....	7
The Inspection.....	8
Qualifications and Experience of Inspection Operatives.....	8
The Chimney Inspection Report.....	9
Remedial Works .....	10
Interval Between Inspections and Historical Background Information .....	10
Appendix 1 – Glossary of Common Terms and Drawings of Typical Chimneys .....	12
Appendix 2 – Typical Terminations of Structural Shells and Liners.....	18
Appendix 3 – Guy Details .....	19
Appendix 4 – Typical Content for use in an Inspection Enquiry .....	19
Appendix 5 – Specialist Ladder Access .....	21
Appendix 6 – Table for Recommended Frequency of Inspections .....	22
Appendix 7 – High Risk Chimneys.....	25
Appendix 8 – New Technologies – UAV or Drones .....	26
Appendix 9 – Training and Competence for Access Specialist Workers.....	27

## Foreword

This Inspection Guide for Steel Chimneys builds upon both the HSE GS53 document and the ATLAS guidance document '***Guide to the Inspection of Single Flue Industrial Steel Chimneys***'.

## Preface

This Good Practice Guide has been created to provide information based around a practical approach that can be used to safely and thoroughly inspect & maintain steel chimneys. This guidance is one of a series of guides that have been drawn up by ATLAS to provide valuable information to its members and industry.

The methods contained within this guide are, at the time of writing, generally available and considered good practice when correctly and safely adhered to.

Readers are advised that only suitable persons having appropriate competence, training and physical fitness should be allowed to work at height and to carry out the task at hand.

Year after year, construction workers in the height industry are killed or injured whilst at work due to misuse of plant and equipment, inadequate training and failure to plan work properly. Whilst these figures have improved over the years, the aim should be to have zero incidents.

These improvements have been achieved by employers taking the initiative in endeavouring to create a safe place of work for their employees and others affected by their acts. This is often more readily achievable when like-minded companies come together within one organisation such as ATLAS, to set standards and good practise for their industry.

ATLAS are all too aware of the effect that deaths, injuries and ill health cause to families, friends and work colleagues. They are also aware of the cost in industrial injury claims, medical treatment, and lost time at work. Furthermore, poor inspection and maintenance can lead to companies facing excessive costs to correct such works and in the worst cases plant shutdown and prosecution of company directors.

This guide has therefore been created to ensure that the works undertaken are to a high standard and any safety or structural incidents are kept to a minimum.

The aim of this guide is to assist those involved in construction but is specifically aimed at the working at height and specialist access sectors. The guidance is simple and may have general relevance to others in the construction process, but particularly for those directly involved with inspecting steel chimneys.

ATLAS is the leading organisation in the UK in relation to the inspection of steel chimneys and is currently involved in producing further guides for the industry.

To ensure a continuous high standard in relation to specialist access work, ATLAS members are strictly regulated. You may therefore be reassured that member companies will be consistent in the high level of service and standards they provide in all matters relating to health & safety.

**Jason Harfield**  
(President) ATLAS

# Client Inspection Guide – Part 1 – General

## Introduction

The purpose of this document is to help clients and / or their nominated representatives prepare for an inspection of an industrial steel chimney, indicate ideally what documentation they should give the contractor and steps they should take prior to and after, work being undertaken. It provides information detailing what should be expected from the contractor prior to and during an inspection, including the qualifications of the inspecting operatives and the type of report that should be presented after the inspection is complete.

For the purpose of this document the term steel chimney is used, however a vent can be considered in many cases to be as critical and for the purpose of this document the same as a chimney.

This Code of Practice refers to all types of plant and production processes on which a chimney or vent is installed, this document does not include chimneys used for domestic purposes.

In addition, there are appendices which give:

1. Glossary of common terms and drawings of typical chimneys
2. Typical terminations of clad structural shells and liners
3. Details of guy systems
4. Typical specifications for requesting the inspection of a steel chimney
5. Specialist ladder access
6. Table for recommended frequency of inspections
7. High risk chimneys
8. New technologies - UAV or Drones
9. Training and competence for specialist access workers

This document, although covering most typical installations, cannot cover every type of steel chimney or situation but it will allow you, as the client, to have a better understanding of how to prepare and what to expect prior, during and following an inspection.

## Why Inspect a Chimney?

An inspection can be either part of a planned maintenance shutdown or in response to a specific obvious problem.

Steel chimneys are complicated, wind sensitive structures and problems experienced are often very specific to this type of structure. Often the major cause of problems can be linked to corrosion, erosion, poor design, poor manufacture or poor maintenance.

If an inspection is undertaken during a planned shutdown this can be executed within an established time frame. If the inspection is reactive to a problem occurring, then there may have to be an unscheduled plant closure resulting in disruption and potentially loss of production.

An unforeseen chimney failure has the potential to result in the immediate shutdown of plant leading to loss of production, heat, steam, hot water etc. and would undoubtedly require the HSE to be notified of a dangerous occurrence - **RIDDOR**

A chimney that is properly inspected and regularly inspected in accordance with the *ATLAS Inspection Guide* and is adequately maintained will remain a cost efficient asset capable of providing years of service normally beyond its original design life.

## The Law

There is a range of legislation relevant to the inspection of an industrial chimney and in particular the specialist access required to access these types of chimneys, these include:

1. The Health and Safety at Work Act
2. The Work at Height Regulations
3. The Management of Health and Safety at Work Regulations
4. The Construction (Design and Management) Regulations
5. The Lifting Operations and Lifting Equipment Regulations
6. The Personal Protective Equipment at Work Regulations
7. The Provision and Use of Work Equipment Regulations
8. The Confined Space Regulations
9. Control of Asbestos Regulations
10. The Waste Regulations

# Guidance Document

## 1. The Safe Use of Ladders in the Specialist Access Industry (ASG 001)

### The Client

The client should follow these basic steps to ensure a safe, competent and proper inspection of a chimney: -

- 1) Understand and plan when the inspection is to be undertaken – ideally this should be when the plant is on a shut-down and the chimney is off-line.
- 2) Prepare a specification for the works – three typical specifications are contained in Appendix 4. ATLAS or an independent chimney professional should be able to provide you with further information.
- 3) The inspection enquiry should be sent to a number of reputable, experienced companies. Such as an ATLAS member company. Names of companies who undertake this work can be found on the ATLAS website, [www.atlas.org.uk](http://www.atlas.org.uk)
- 4) Having selected a competent contractor, you, or your nominated representative, as the client must observe the various laws which cover the type of work to be undertaken. This will include completing a risk assessment to establish who potentially will be at risk whilst the work is undertaken and the appropriate steps that need to be taken to control and reduce the risks. This risk assessment will include the contractor's operatives and perhaps your own staff, as well as other visitors to your site and even the general public.
- 5) You should issue the successful contractor with following documentation, if it exists or state that there are no records. This information should include but not necessarily be limited to:
  - a. A construction drawing of the chimney.
  - b. Historical inspection reports highlighting any major defects, repairs or modifications to the chimney.
  - c. Whether recommended remedial works indicated in the last report have been carried out.
  - d. Any changes in boiler fuel or structural alterations that have been made to the chimney since it was last inspected.
  - e. Any information which might be deemed necessary to allow the contractor to prepare for and undertake the works in a safe method.
  - f. View of the asbestos register for the site. Many chimneys built prior to 1990 may contain varying amounts of asbestos.
  - g. Refer to Appendix 5. – Specialist Ladder Access.
- 6) Prior to the work commencing you must obtain a task specific risk assessment and method statement (RAMS) from the contractor with adequate time to allow you, or your nominated representative, to review the RAMS. It is essential that a safe system of work is established from the planning of the works and all risks have been considered and control measures, to reduce the risks identified, applied. The contractor must also display within the established safe system of work, an ability to carry out a Point of Work risk assessment.
- 7) Prior to the works being undertaken establish if there is any preparatory work that you must or have agreed to undertake such as:
  - a. Isolation of plant including but not limited to the process the chimney serves and if applicable electrical isolations and lock off procedures are available, fully functional & understood by all those involved with the project.
  - b. Erecting safety barriers and warning notices to provide a safe work area and protect others.
  - c. Provide safe access over roofs or erection of edge protection or temporary access scaffolds.
  - d. See Appendix 5 – Specialist ladder access.
- 8) When the contractor's operatives arrive on site they should be given a site specific induction clearly highlighting the risks and hazards they might encounter on the site, any special site restrictions or safety measures they must obey and any other relevant information connected with the works to be undertaken.
- 9) You should monitor that the contractor's operatives understand, follow and adhere to the established safe system of work that should include as a minimum a task specific risk assessment and method statement, your site rules, your site permit's and all other control measures and procedures established for the work to be undertaken safely.
- 10) It is also advisable that prior to the contractor leaving site you should check that there is no work which must be undertaken as a matter of urgency to ensure the chimney remains safe and possesses no immediate hazards.

- 11) You should expect a written report within an agreed time frame, which would normally be within 21 days after the inspection has been completed

## The Contractor

- 1) The appointed contractor should be able to demonstrate that:
  - a. They are experienced & competent to undertake the required inspection work and that they understand the type chimney they will be inspecting and can provide evidence & references if requested.
  - b. Their operatives undertaking the work are experienced and competent to safely complete the tasks they will be required to undertake and possess recognised industry qualifications. As a minimum this qualification should be an NVQ Level 2 in Steeplejacking, copies of training certificates and qualifications should be provided with evidence of continuous training having taken place.
  - c. Provide a risk assessment and method statement prior to the work being undertaken which clearly demonstrate they understand the risks, have assessed them and implemented adequate control measures to manage the risks.
- 2) The contractor should agree with you when the work will be undertaken and plan for their operatives to arrive at the prescribed time and date to attend your site specific induction.
- 3) If for whatever reason a need is identified to deviate from the established safe system of work, then prior to the work commencing and as part of the safe system of work the contractor must be able to display their capability to undertake a Point of Work risk assessment. As a minimum this will see the work stop until the Point of Work risk assessment has been completed, understood and disseminated to all those involved with the work.
- 4) If during the course of the inspection major problems are identified with the chimney that have the potential to bring into question the stability of the chimney or its ability to remain in service, a procedure must be in place to ensure such findings are immediately reported to the person/s responsible for the asset.
- 5) A written report complete with conclusions and recommendations will be issued within an agreed time following completion of the inspection. Providing nothing of any structural importance has been identified, this reporting period should not usually exceed 21 days.



# Client Inspection Guide – Part 2 – Site Works

## The Inspection

- 1) The exact nature and detail of the inspection will depend upon the actual chimney being inspected. Below is a list of the main types of steel chimneys, individual inspection criteria for each type of chimney can be downloaded from the ATLAS website [www.atlas.org.uk](http://www.atlas.org.uk). There may be other areas which should also be checked due to a specific/ bespoke design, construction or position of the chimney, but a competent inspector should know any additional checks that may be required.
- 2) It should be appreciated that different steel chimney design codes recommend different inspection intervals (See P.9 Intervals between inspections and historical information) and in addition the actual condition and age of the chimney can also influence the frequency at which inspections should be undertaken.
- 3) The inspector should record ultrasonic thickness readings, and make notes of what he is viewing. This should be supported by taking photographs throughout the height of the chimney to assist with capturing the general condition of the chimney with the focus being on any obvious defects.
- 4) If there are no drawings of the chimney and it is over 10 years of age or in poor condition it is recommended that dimensions of the chimney including but not limited to diameter, overall height and section lengths, flange, inlet, door opening and base details plus any other fittings such as test ports, ladders and platforms are obtained and recorded.
- 5) Refer to Appendix 5. of this document prior to installing specialist access ladders to facilitate access for carrying out a chimney inspection. ATLAS remind all contractors that the use of specialist access ladders to inspect a chimney must only be considered once the hierarchy of control has been applied and a risk assessment completed.

The following documents may be freely downloaded from the ATLAS website [www.atlas.org.uk](http://www.atlas.org.uk) and give details of the work a contractor should undertake when inspecting a chimney.

- Single Skin Chimney – Free Standing
- Bracketed Chimneys
- Stayed Chimneys
- Liners Contained within a Concrete or Brick Chimney or within a Shaft in a Building
- Lined Chimneys or Liners
- Multiflue and Double Skin Chimneys – Free Standing
- Guyed Chimneys
- Clad and Insulated Chimneys
- System Chimneys (Sectional Factory Built Chimneys)
- Masts and Support Structures

## Qualifications and Experience of Inspection Operatives

- 1) As a minimum all operatives should hold the following:
  - a. A current CSCS NVQ Steeplejack Skills Card
  - b. A current asbestos awareness certificate
  - c. A current Confined Space certificate (if entering a confined space or responsible for others working within one)
  - d. A suitably trained and qualified rescuer capable of executing a rescue at height
- 2) The lead inspector should be competent and experienced in undertaking steel chimney inspections.
- 3) The inspector undertaking the ultrasonic thickness readings should be proficient in the use and interpretation of Ultra Sonic Thickness testing apparatus. The inspector should possess as a minimum a **BS EN ISO 9712 PCN RTO/UT1** qualification and hold a current certificate.

**Note:** From January 2017, PCN rectification examinations are required to be completed six weeks prior to the expiry date

- 4) If, after applying the HSE hierarchy of control, powered access is the preferred method of access to be employed (e.g. mobile elevated work platform (MEWP), mobile crane and man-ride basket, suspended access cradle) then a trained and competent supervisor and operator must be present and in control of the equipment at all times.
- 5) If, after applying the HSE hierarchy of control the use of specialist ladder access is the option selected to access the chimney, those undertaking the access works must possess an industry specific NVQ skill card in steeplejacking, and be able to demonstrate competency supported by continuous training and experience.

Prior to installation of the specialist ladder access refer to Appendix 5. of this document – specialist ladder access.

## The Chimney Inspection Report

The report should be laid out in a clear and logical manner with the following topics covered:

- 1) Introduction
  - a. The date when the inspection was carried out
  - b. Who undertook the inspection and their industry recognised qualification/s
  - c. Weather conditions
  - d. Testing apparatus used i.e. identification number and confirmation of calibration
  - e. A basic description of the chimney being inspected
  - f. A short description of the work undertaken including method of access used to complete the inspection.
  - g. Clearly indicate any work specified but not undertaken and why it was not carried out; this might be that the chimney was too dangerous to access by the intended manner, an item was too fragile to remove or installed in a non-conventional manner, time constraint, plant on line etc.
- 2) Report
  - a. The report should include a description of all areas inspected which should be laid out in a chronological order working down or up through the height of the chimney for ease of reference.
  - b. Photographs should be included showing both general views and detail of any defects found. These should be annotated to clearly state the feature and its relevant position. There should not be a myriad of photographs as this can be confusing especially if not clearly labelled.
  - c. The ultrasonic results should be tabulated or accurately entered on a schematic drawing plotting the location of the readings obtained.
- 3) Conclusions
  - a. The conclusions and recommendations drawn from the inspection should be clearly stated.
  - b. Ultrasonic results should be compared to the original material thickness taken from the drawings, if available, or previous inspection reports. Where this information is not available, a competent and experienced company should have the capability to advise on what minimum steel thickness would have been typically used in construction.
- 4) Recommendations
  - a. If there are areas which have caused the inspector concern, then a separate report should be commissioned using a specialist chimney designer to undertake a design review to ensure the chimney meets current design criteria.

This would include but not be restricted to confirming:

    - i. Location and proximity of any adjacent structures
    - ii. Flange thickness and bolt size
    - iii. Inlet and opening reinforcing
    - iv. Ultrasonic thickness readings
    - v. Lightning protection.
    - vi. Anti-mass vibration damping
    - vii. Holding down arrangement
  - b. Any recommendations for remedial actions should be clear laid out and state possible consequences if the work is not undertaken.
  - c. Each recommendation should be critically ranked:
    - i. Critical                      Must be undertaken at the earliest opportunity.
    - ii. Necessary                    Should be undertaken within the next 12 months
    - iii. Advisory                    Can be left until the next inspection
  - d. A date when the next inspection should be undertaken in line with both the relevant inspection code and the condition of the chimney which may identify a requirement to inspect more frequently than the normal recommended interval (usually 24 months).
- 5) Costings
  - a. These maybe included if desired but it is recommended that they are sent with the report as a separate item.

The report should be sent with a covering letter drawing the client to any particularly relevant or salient points contained within it.

## Remedial Works

The majority of remedial work will usually not require an independent qualified structural engineer to be involved. However, if structural repairs are required such as the over-plating of thin areas of steel, flanges are in poor condition, failed bolts/fasteners, strengthening works where the existing reinforcing is considered not sufficient, then a competent engineer with specialist chimney design knowledge and skills should be engaged.

This would also apply if a chimney requires modification to meet revised operating methods such as a change in boilers or boiler fuel, the addition of a new inlet or test ports or the fitting of a sampling platform and access ladder. These items can all have a significant effect on the structural performance of a chimney and must be properly designed by a competent chimney engineer.

Remedial works which should be undertaken include but are not limited to:

- 1) Any work that has been recommended following a specialist chimney structural engineer's report.
- 2) Repairs to a damper system or helical stabilisers. These items are vital in preventing a chimney from suffering fatigue due to cross wind oscillation; if not properly maintained the result could be catastrophic.
- 3) Painting works to protect against corrosion. However, the recommendation to paint cladding is often only an aesthetic undertaking and not a necessity, it will involve ongoing costs to keep the finish looking satisfactory especially if the work is not properly undertaken i.e. cleaning and etching the existing surface before painting.
- 4) Replacement of flange bolts if they have been tested in a laboratory and deemed unfit for continued use.
- 5) Repairs to cladding, re-riveting and sealing any gaps where weather might penetrate.
- 6) Unblocking of drain pipes. These should not be left open but plugged to stop cold air being drawn into the system.
- 7) Placing or replacing the grout under the baseplate. The placement of grout is vitally important as this helps transmit the loads induced in the chimney to the foundation

## Intervals Between Inspections and Historical Background Information

The HSE recognise and support ATLAS in recommending that a steel chimney and in particular a single flue self-supporting chimney, is potentially very susceptible to structural failure and therefore must be regularly inspected and maintained in a suitable condition to ensure that its structural performance is not compromised (see Appendix 7).

It is acknowledged that different steel chimney design codes and standards recommend different intervals between inspections. However, it should be appreciated and clearly understood that as with the recommendations in this document, inspection intervals are recommendations and key factors such as age, condition or location (i.e. coastal) of a chimney may ultimately have a greater bearing in dictating the inspection frequency.

If there is any uncertainty surrounding which inspection frequency should be applied to which chimney the following information and the tables in Appendix 6. offer clear guidance. In addition, ATLAS would emphasise that for all high risk self-supporting single flue steel chimneys, the HSE document **GS53** recommends inspection intervals of **Every 14 months**.

In addition to the above HSE recommended 14-month inspection period for high risk chimneys, the ATLAS document '**Guide to the Inspection of Single Flue Industrial Steel Chimney**' which builds upon **GS53**, recommends the following for externally insulated high risk chimneys; -

*If internal access to the chimney is not possible, remove all external cladding and insulation to enable a detailed ultrasonic thickness survey to be undertaken throughout the full height and circumference of the chimney. \*Note- This procedure should also be considered if no design details are available and/or the chimney has not been inspected to the required detail in accordance with the recommended time periods described in this document.*

- 1) Following a survey in 1992 the HSE produced a Guidance Note **GS53** with reference to single flue steel chimneys (the windshield is both structural and gas carrying). In 2004 ATLAS produced '**The Guide to the Inspection of Single Flue Industrial Steel Chimneys**' which recommends this type of chimney is inspected annually, reducing the HSE **GS53** period recommendation of 14 months. (See Appendix 6.)
- 2) The majority of the steel chimneys currently in service throughout the UK were built to **BS 4076 Specification for Steel Chimneys** and although the 1989 edition was withdrawn in 2010, many smaller chimneys are still built to this standard. An appendix at the rear of **BS 4076:1989** recommended that chimneys were inspected one year after erection and then every three years.

- 3) There are an increasing number of chimneys built to the **CICIND Model Code for Steel Chimneys** (first published 1999). These are normally tall chimneys up to heights of circa 100 metres and can exceed circa 3.5m in diameter. Some of the basics of this code are often used when designing to **BS4076**. This **CICIND Model Code for Steel Chimneys** recommends inspections at two yearly intervals.
- 4) Other current recognised chimney build standards are **Eurocode 3 – Design of steel structures - Part 3-2: Towers, masts and chimneys - Chimneys** and **BS EN 13084-7:2013 Free-standing chimneys. Product specifications of cylindrical steel fabrications for use in single wall steel chimneys and steel liners**. Other documents in the **BS EN 13084** series are also relevant. Mainly larger chimneys are built to these standards and as with the CICIND code, this standard also recommends an inspection interval of two years.
- 5) ATLAS do not consider large chimneys manufactured from GRP to be industrial steel chimneys, albeit many of the recommendations and procedures contained in this document could be applied to the inspection and maintenance of a chimney manufactured from GRP.
- 6) ATLAS do not consider system chimneys (twin wall factory assembled units) produced to **BS EN 1856 parts 1 & 2 2009** to be industrial steel chimneys. This code gives no recommendations as to the frequency of inspections.

In addition to the above:

- 1) If a lightning protection system is fitted it should be inspected and tested according to either **BS6651**, if this was the relevant lightning protection standard at the time of installation or the latest version of **BS EN 62305** the standard for lightning protection, and a compliance certificate produced upon completion of the testing of the system.  
  
**Note:** *If installation is in accordance with **BS EN 62305** a minimum of 2no diametrically opposed independent earth locations should be installed to a steel chimney.*
- 2) Any permanent ladders and platforms fitted which, following the completion of a risk assessment, could be accessed for completing a chimney inspection or by others (e.g. for environmental monitoring) should be inspected annually and a certificate of compliance issued.
- 3) Any climb-safe system fitted which could be used by others than qualified operatives should be tested annually and a certificate of compliance issued. It should be appreciated that with some climb-safe/man fall systems the anchor securing the system at the chimney summit cannot initially be confirmed in relation to its condition. Chimneys often exhaust corrosive fumes which could attack the top anchor, potentially bringing the reliance on the system installed to arrest a fall, in to question.
- 4) It is recommended that any access doors to chimneys or liners are opened annually and any debris / waste material removed and disposed of in compliance with the Waste Regulations 2015. This is something which the client could undertake themselves subject to adequate control measures being established.

## Appendix No 1 – Glossary of Common Terms and Drawings of Typical Chimneys

The numbers in brackets refer to the items as shown in the drawings showing typical chimney designs.

**Access door** (2.01) – A door for the entry of personnel or other means of inspection.

**Aerodynamic stabilizer** (2.03) – A device fitted to the structural shell to reduce wind excited oscillations by modifying vortex shedding.

**Anchor bolts** – see Holding down bolts.

**Base cone** (2.04) – A truncated cone incorporated immediately above the baseplate of a chimney.

**Baseplate** (2.05) – A horizontal plate fixed to the base of a chimney. *Also called a bearing plate.*

**Base stool** (2.07) – A construction comprising two vertical plates, welded to the chimney shell and to the baseplate, supporting a compression ring (2.14) through which a holding down bolt passes.

**Blanking off plate** (2.08) – An imperforated plate fitted immediately beneath the inlet of a chimney to prevent the waste gasses reaching the lower portion of the chimney. *Also known as a false bottom.*

**Boiler mounted chimney** – A chimney supported by a boiler and its foundation.

**Bracket** (2.10) – A construction providing resistance to lateral displacement of the chimney and/or supporting part or all of the weight of the chimney.

**Bracketed chimney** (2.11) – A chimney in which not all external applied loads (e.g. wind) are carried exclusively by the structural shell and for which brackets, attached to an adjacent structure, are provided to ensure stability. *Also known as a braced chimney.*

**Breeching** – see inlet (2.28)

**Cap plate** (2.12) – A sloping or convex plate fitted to the top of the structural shell, covering the area between it and the liners and incorporating cravats through which the liners protrude.

**Cleaning door** (2.13) – A door, normally at the base of the chimney, to permit the removal of flue dust.

**Compression ring** (2.14) – A steel plate welded to the shell which transfers the forces acting upon the chimney to the holding down bolts. *Also known as a base ring.*

**Cope band** (2.16) – A steel section attached to the top of the chimney around its perimeter to give added strength and corrosion resistance at this level.

**Cope hood** (2.16) – A hood fitted externally to the top of a liner, covering the upstand of the cap plate, to prevent the ingress of rain water.

**Corrosion test piece** (2.17) – A fixed or removable steel plate insert, generally of lesser thickness than the shell of the chimney, in contact with the waste gasses and fitted at strategic points where maximum corrosion is expected.

**Cowl** (2.18) – A conical or dished cap fitted to the top of a chimney to reduce the ingress of rain water. *Also known as a rain cap.*

**Cravat** (2.19) – An upstand fixed to the roof, roof plate or cap plate to prevent the ingress of rain water (see cope hood). *Also known as a counter flashing.*

**Cross-section** – The section of the load bearing steel shell including the corrosion allowance.

**Damping device** (2.20) – A device fitted to the structural shell to increase its structural damping.

**Doubling plate** (2.21) – A plate fixed to the shell to reinforce it where increased forces occur.

**Double skin chimney** (2.22) – A chimney consisting of an outer load-bearing steel shell and an inner liner which carries the flue gasses. *Also known as a dual wall chimney.*

**Drag coefficient** – see wind force coefficient.

**Drain pipe** (2.23) – A pipe which connects a tundish or blanking off plate to a point outside the structural shell or liner and used to remove condensate.

**Flue** – See liner

**Guy** (2.24) – A wire rope attached at one end to a chimney and anchored at the other end so as to provide tensile resistance to the lateral displacement of a chimney.

**Guy band** (2.25) – A steel section fitted around the outside of a chimney with the provision for the attachment of guys.

**Guyed chimney** (2.26) – A chimney in which is not all external applied loads (e.g. wind) are carried exclusively by the structural shell and for which guys are provided to ensure stability.

**Holding down bolts** (2.27) – Bolts built into a concrete foundation, brick base or supporting framework to provide anchorage at the base of the chimney.

**Hoops** – Horizontal rings forming a cage around ladders.

**Inlet** (2.28) – A short duct fixed to the shell or baseplate of a chimney for the entry of flue gases.

**Intermediate cone** (2.29) – A truncated cone incorporated in the chimney shell at an intermediate level.

**Jointing flange** (2.30) – A steel section fitted to the end of a chimney section to enable sections to be connected together.

**Ladder boss** – A boss welded to the chimney shell into which an access hook or eye can be screwed to provide fixing for temporary ladders.

**Lateral support** (2.31) – Supports positioned at appropriate levels within the structural shell to locate liners, allowing independent expansion of the shell.

**Lightning protection system** – System to provide electrical continuity between the chimney and earth.

**Liners** (2.32) – Flue gas ducts contained within the structural shell.

**Liner base** (2.33) – A suitable support positioned at a convenient height above the baseplate of the structural steel shell to carry the weight of the liners.

**Lining** (2.34) – A material applied to the internal face of the chimney to prevent the flue gases contacting the inner surfaces of the steel shell.

**Multiflue chimney** (2.35) – A group of two or more chimneys within a structural framework or a chimney comprising of a group of two or more liners within a structural shell.

**Nett section** – The section of the load bearing steel shell without corrosion allowance.

**Reinforcement** – Structural shapes or plates at or near to shell apertures to strengthen the shell.

**Roof plate** (2.36) – A plate which follows the contour of the roof round the chimney where it passes through the roof of a building. *Also known as a flashing.*

**Rungs** – Horizontal bars in a ladder.

**Safety system** – Proprietary fall arrest system fixed to ladder rungs or besides the ladder to give a safe fixing for attachment of operatives' safety harnesses.

**Self-supporting chimney** (2.37) – A chimney in which externally applied loads (e.g. wind) are carried exclusively by the structural shell and which, together with the foundations, will remain stable under all design conditions without additional support.

**Splitter plate** (2.38) – A vertical plate welded to the interior of the shell between two horizontal opposed inlets to divert the flow of the flue gasses into a vertical direction and to inhibit the passage of flue gasses from one inlet to the other.

**Stay** (2.39) – A rigid member providing both tensile and compressive resistance to the lateral displacement of the chimney. *Also known as a lateral brace.*

**Stayed chimney** (2.40) – A chimney in which not all the applied loads (e.g. wind) are carried exclusively by the structural shell and for which stays, connected to another structure, are provided to ensure stability.

**Strakes** – See Aerodynamic stabilizers.

**Stringer** – Vertical member of a ladder to which rungs are attached.

**Structural shell** (2.41) – The main external structure of the chimney, excluding any reinforcing or flanges.

**Top cone** (2.43) – A truncated cone or other device fitted at the top of a chimney to increase the gas exit velocity.

**Tundish** (2.43) – A conical or sloping blanking plate provided with facilities for drainage. *Also known as a false bottom.*

**Tuned mass damper** – A form of damping device which employs a pendulum, tuned to the chimney's natural frequency. The moving part of the pendulum is connected to the chimney by an energy absorbing device.

**Vanes** – See Aerodynamic stabilizers.

**Venturi** – See Top cone.

**Weatherhood** (2.44) – A hood designed to shed rain water clear of the cravat and prevent its entry into the building. *Also known as counter flashing*

**Drawings of Typical Chimneys – Numbers Reference the Descriptions Provided in Appendix 1.**

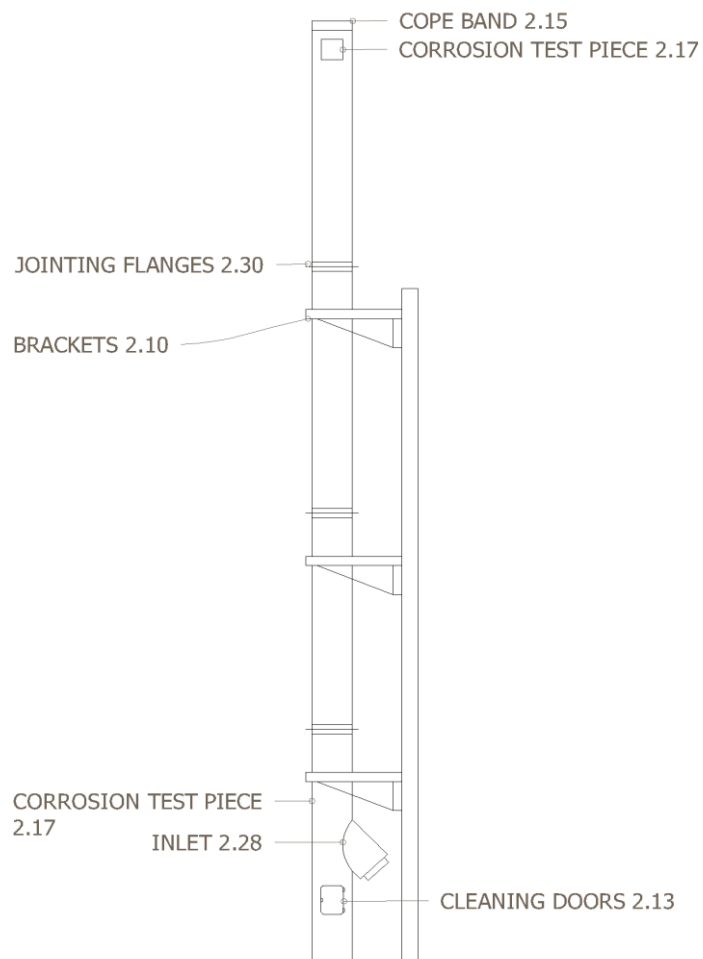

**BRACKETED SINGLE  
FLUE CHIMNEY  
2.11**

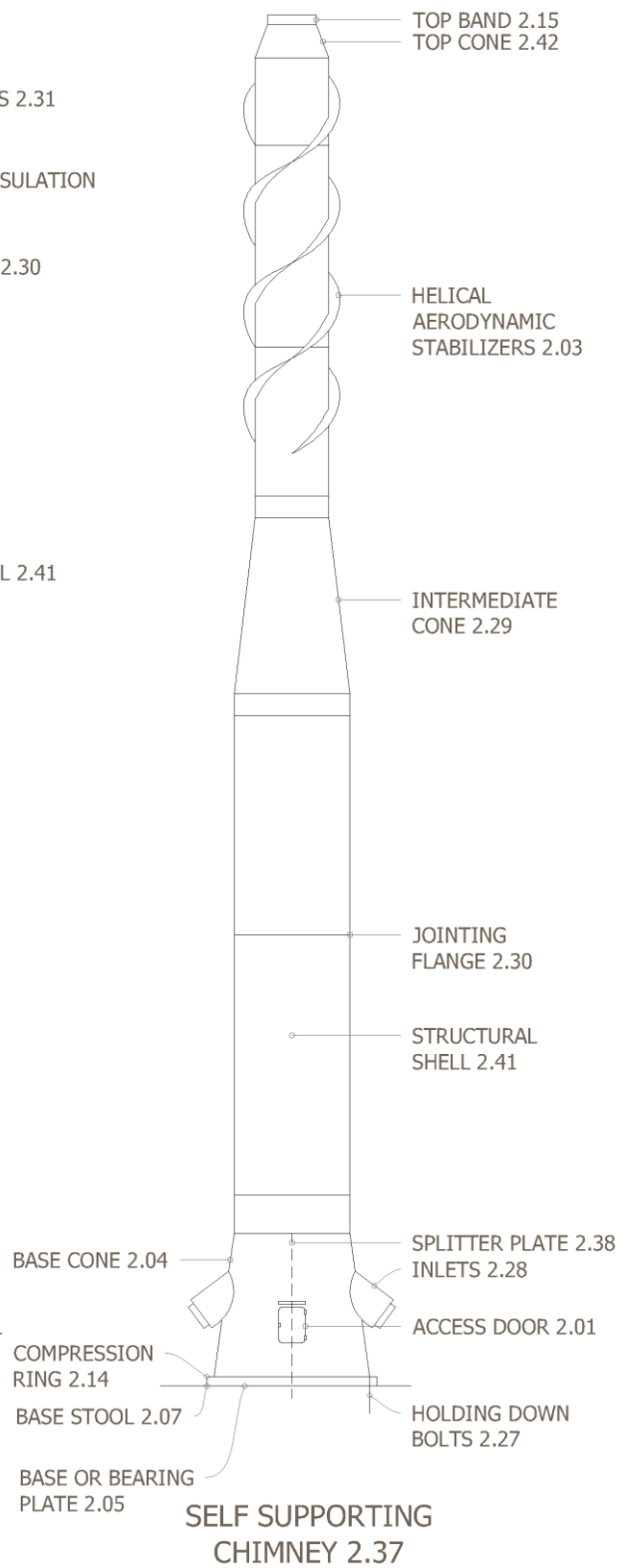
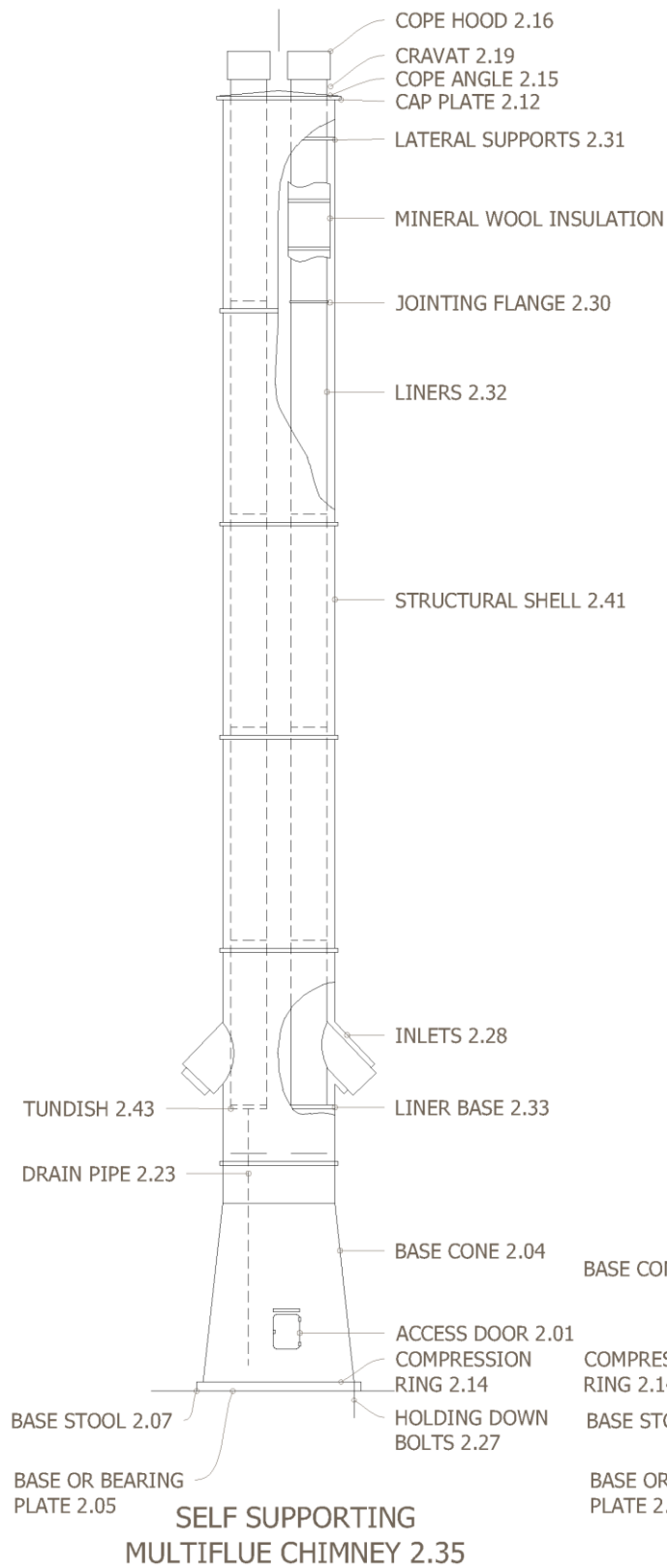



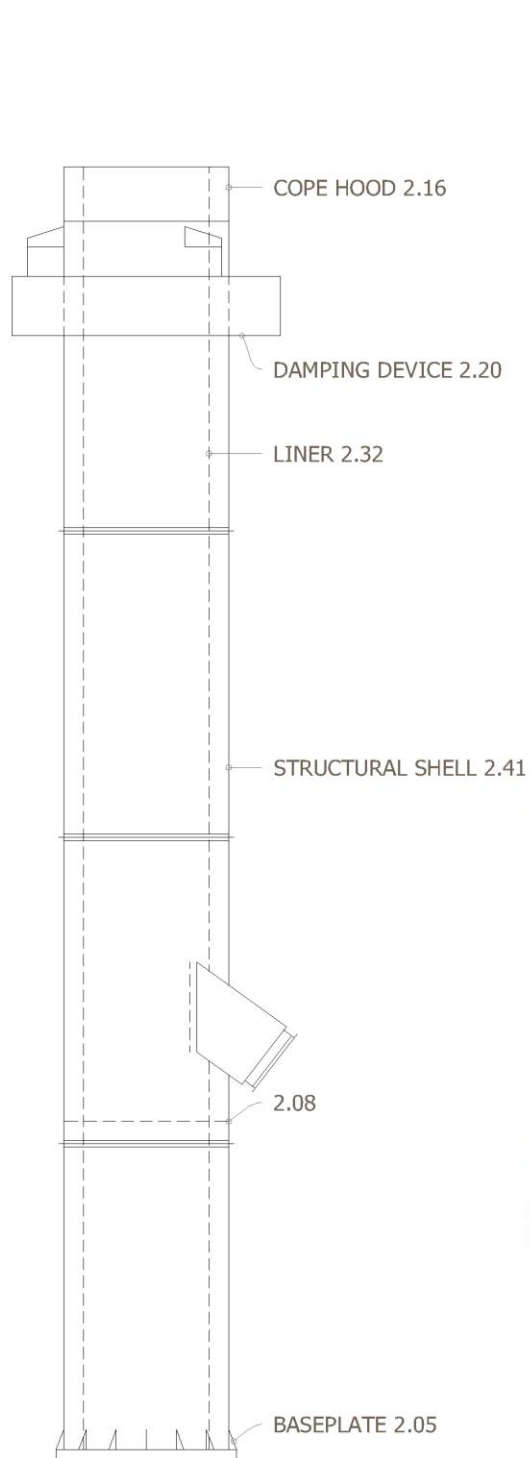

DOUBLE SKIN  
CHIMNEY 2.37

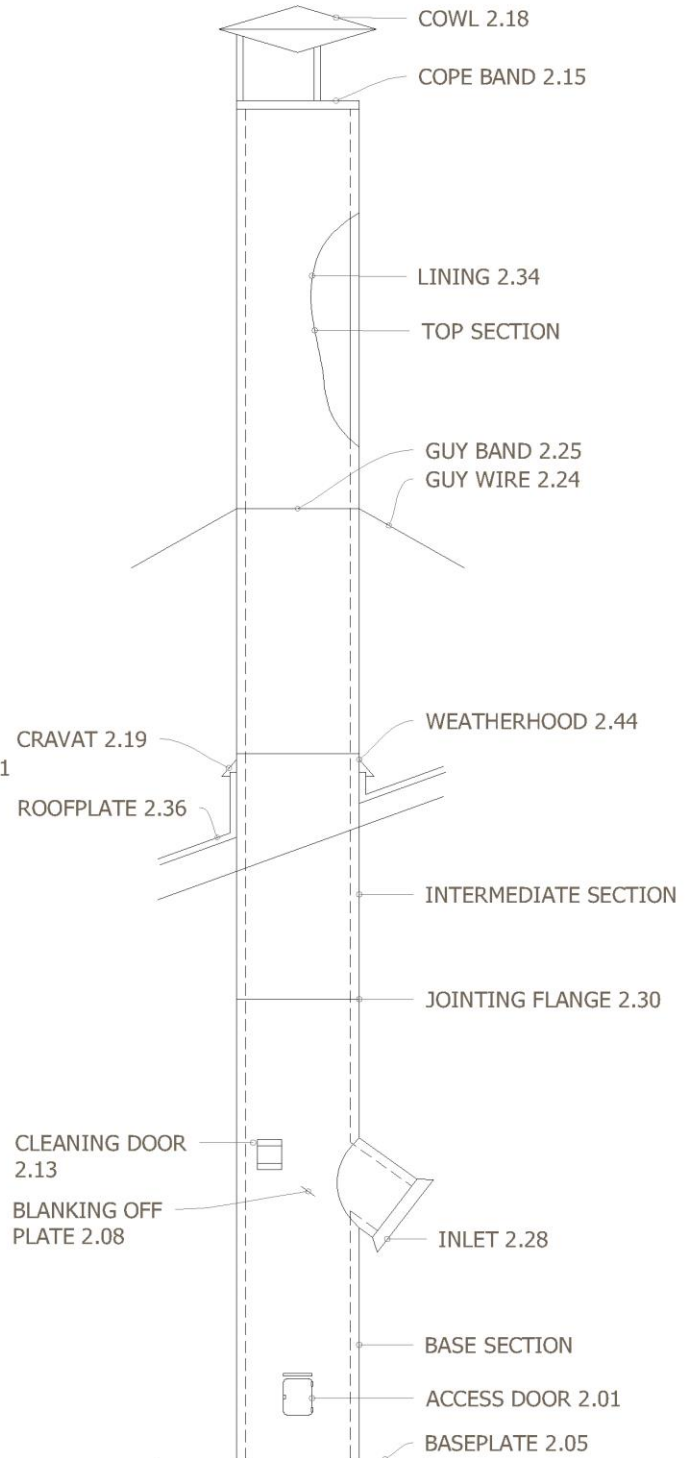

GUYED CHIMNEY 2.37

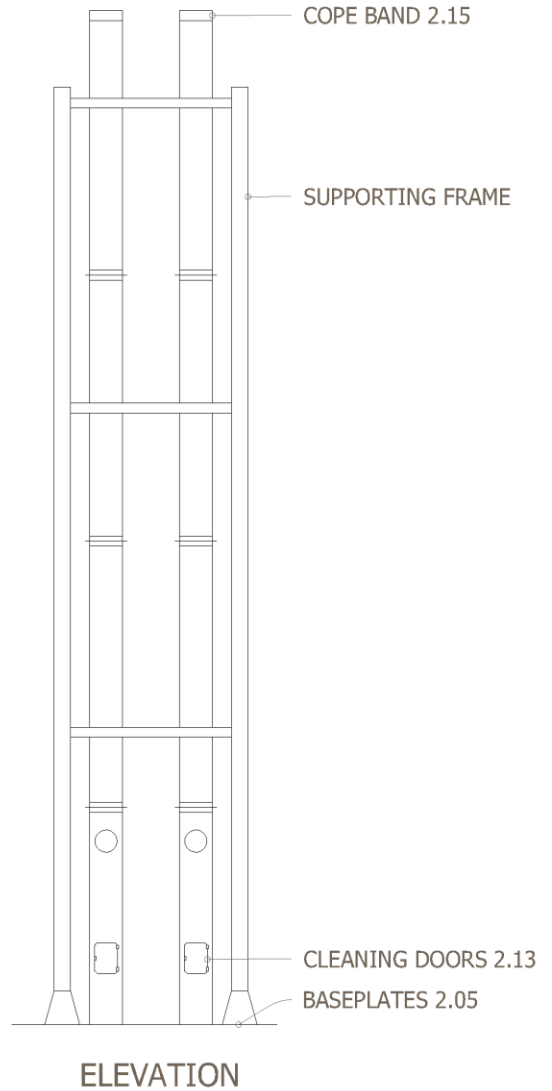
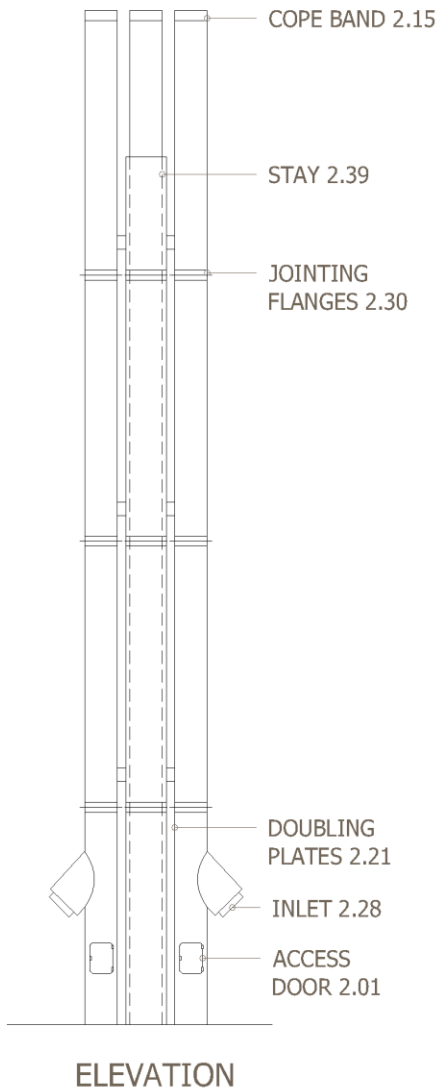
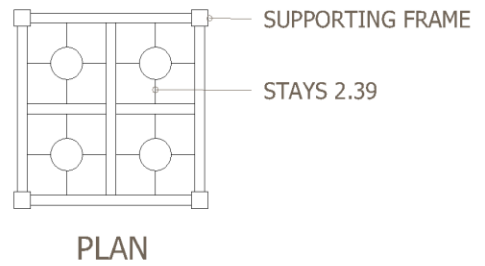

STAYED CHIMNEY WITH THREE FLUES  
(EXTERNAL FRAME) 2.40

STAYED CHIMNEY WITH FOUR FLUES  
(EXTERNAL FRAME) 2.40

## Appendix 2 – Typical Terminations of Structural Shells and Liners

Figure 3: Top of clad structural shell or liner

### Top of clad structural shell or liner

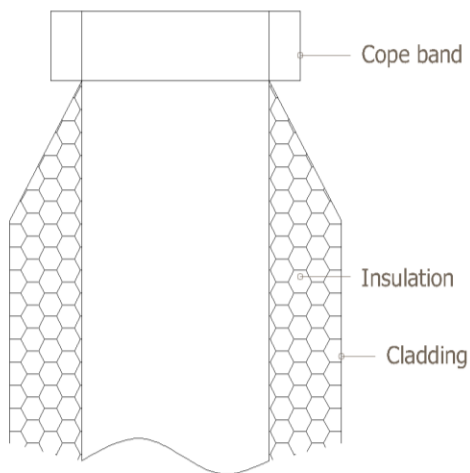
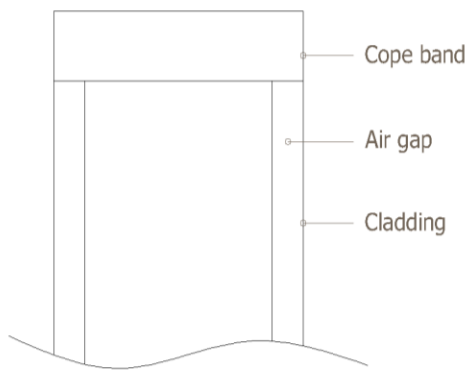

Incorrect

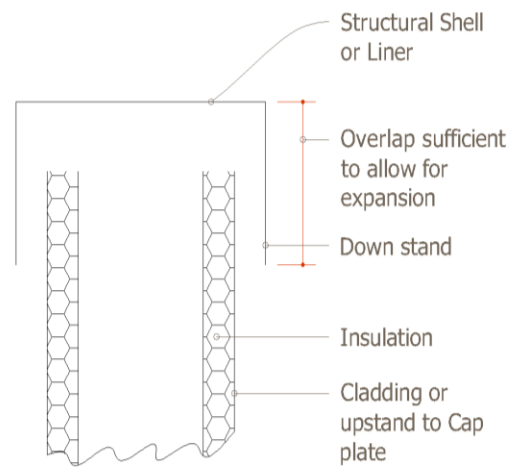

Correct

## Appendix 3 – Guy Details

1. Guys must be manufactured from wire rope and have a steel core (NOT fibre). If a fibre cored guy is fitted it must be changed.
2. The bulldog grips/ wire rope grips should conform to EN 13411-5 & DIN 1142 and fitted. These should be fitted with the saddle on the main wire not the tail (never saddle a dead horse) and at equal intervals which equate to between 1.5 and 3 times the width of the saddle.
3. The number of bulldog grips fitted to a guy termination varies with the diameter of the wire. Below are typical wire sizes and the number of clips which must be fitted.

<b>Dia. Wire</b>	<b>6</b>	<b>8</b>	<b>10</b>	<b>12</b>	<b>16</b>	<b>19</b>	<b>22</b>
<b>No. Clips</b>	<b>3</b>	<b>4</b>	<b>4</b>	<b>4</b>	<b>4</b>	<b>4</b>	<b>5</b>

4. There must be a minimum of 3no guys per level.
5. Guys should be angled at between 45° and 60° from ground level. The angle between adjacent pairs of guys should not exceed 130°.
6. The turnbuckle should have either lock nuts either side of the barrel or another locking system to stop it being able to come loose.
7. The tension in each guy should be measured using a suitable instrumentation method (dynamometer or tension meter). The measurements should be undertaken on a calm day and ideally the tension in each guy measured simultaneously to give the most accurate results).
8. The guys should be adjusted if the recorded tensions are significantly different. The tension in a guy should be not less than 15% and not more than 30% of the maximum tension due to wind.

## Appendix 4 – Typical Content for use in an Inspection Enquiry

### Specifications

The specifications below give an outline for requesting an inspection but will require items to be deleted / added as necessary depending on the actual chimney.

If the site has more than one chimney, then information must be given for each one.

### **Free standing/ Guyed single skin chimney**

We request a quotation for inspecting our chimney/s as outlined below. Inspection to be to the ATLAS CoP for the Inspection of Industrial Steel Chimneys.

The chimney serves a boiler/ process plant/ ..... plant. The inspection maybe undertaken at any time/ due to site constraints can only be carried out during a shutdown/ at the weekend.

You will have to attend a site induction on arrival which will take approximately ..... hrs

1. Chimney approximately ....m high with a terminal diameter of ....mm
2. The chimney was erected in approximately ....
3. We have copies / no copies of any drawings
4. We have / do not have copies of past inspection reports.
5. We enclose a photograph(s) of the chimney to give you a visualisation of the work
6. The chimney is insulated and clad
7. The chimney is manufactured in flanged and bolted sections
8. The chimney has a damper system fitted/ has a .... way guy system fitted at ....no levels
9. There is a ladder running the full height/ to an environmental sampling platform at the approximately ....m height
10. The chimney passes through a roof at the approximately ....m level

### **Single liner or multiflue chimney**

We would request that you quote your best price for inspecting our chimney as outlined below. Inspection to be to the ATLAS CoP for the Inspection of Industrial Steel Chimneys.

The chimney serves a boiler/ process plant/ ..... plant. The inspection maybe undertaken at any time/ due to site constraints can only be carried out during a shutdown/ at the weekend.

You will have to attend a site induction on arrival/ on a ..... which will take approximately ..... hrs

1. Chimney approximately ....m high with a terminal diameter of ....mm
2. The chimney was erected in approximately ....
3. We have copies/ no copies of any drawings.
4. We have/ do not have copies of past inspection reports.
5. We enclose a photograph(s) of the chimney to give you a visualisation of the work.
6. The chimney has ....no liners. ....no at ....mm dia, ....no at ....mm dia, ....no at ....mm dia (repeat as necessary).
7. The chimney is manufactured in flanged and bolted sections. The flanges are external/ internal.
8. There is an internal ladder running the full height with platforms at regular/ flange levels
9. There is an external ladder running the full height/ to an environmental sampling platform at the approximately ....m height.
10. The chimney passes through a roof at the approximately ....m level

### **Bracketed chimney(s) to a building, tower or mast**

We would request that you quote your best price for inspecting our chimney as outlined below. Inspection to be to the ATLAS CoP for the Inspection of Industrial Steel Chimneys.

The chimney serves a boiler/ process plant/ ..... plant. The inspection maybe undertaken at any time / due to site constraints can only be carried out during a shutdown/ at the weekend.

You will have to attend a site induction on arrival/ on a ..... which will take approximately ..... hrs

1. The chimney(s) are fixed to the side of a building/ tower/ mast
2. The chimney(s) is/ are manufactured in flanged and bolted sections
3. The chimney(s) is a/ are sectional factory manufactured system chimney(s)
4. Chimney(s) are approximately ....m high with a terminal diameter of ....mm. (if more than 1no chimney give details of each chimney attached to the structure)
5. The chimney(s) project approximately above the last support
6. The chimney(s) was/ were erected in approximately ....
7. We have copies/ no copies of any drawings
8. We have/ do not have copies of past inspection reports
9. We enclose a photograph of the chimney to give you a visualisation of the work
10. The chimney(s) is/ are insulated and clad
11. There is a ladder running the full height of the mast/ tower
12. The chimney(s) passes through a roof at the approximately ....m level

If you have any questions or queries, please do not hesitate to contact Association of Technical Lightning & Access Specialists at [info@atlas.org.uk](mailto:info@atlas.org.uk)

## Appendix 5 – Specialist Ladder Access

If sufficient information has been made available including previous inspection reports and as built construction drawings, and having applied the Hierarchy of Control and completed a risk assessment it has been established that there is no other access method considered to be reasonably practicable other than specialist access ladders in accordance with the ATLAS document *The safe use of ladders in the specialist access industry* ASG001 November 2014. ATLAS consider the following pre inspection user checks essential prior to commencing with the laddering of a steel chimney:-

**Note** – ATLAS consider it essential and good practice that those tasked with carrying out an inspection using specialist access ladders, inspect the chimney as they ascend up through the height of a structure.

<b>Before laddering a steel chimney ATLAS consider the following to be a minimum to assist with confirming if it is safe to proceed laddering a steel chimney.</b>	<b>Y (✓)</b>	<b>N (✓)</b>
Corroded, hidden, damaged loose holding down bolts?		
Clear evidence 'leaning over' of the chimney off vertical? (25mm over the chimneys full height or 1 – 1000 <sup>th</sup> of the height of the chimney whichever is greater)		
Holes in the chimney walls or any visible linings?		
Evidence at ground level of internal corrosion (viewed through low level inspection door/s or apertures etc)?		
UST readings at the chimney base show the structural plate to be less than 6mm thick		
Excessive corrosion, lamination or staining evident on the chimney as viewed from ground level?		
Sodden insulation/erosion of the external cladding		
Missing pop rivets considered to be excessive?		
Any Splits, cracks, failed welds, bulging, buckling, deformation or distortion on the chimney that is not thought to be within normal parameters?		
Visual evidence of any external impact damage that may have been caused by site plant which could render the chimney potentially unsafe to access?		
If fitted, are guy wires adequately tensioned, any visual damage to the wires or corrosion evident		
<b>Before laddering a steel chimney ATLAS consider the following to be further precautionary that could be carried out to assist with confirming if it is safe to proceed with laddering a steel chimney.</b>	<b>Y (✓)</b>	<b>N (✓)</b>
A build-up of water inside the base of the chimney. Evidence of blocked drain off pipe serving the chimney.		
Standing water around the base of the chimney or any visible seeping from beneath the cladding – if so remove bottom section of cladding to inspect		
Excessive chimney oscillation (movement) visually evident when observed or during any initial access of the chimney?		
Oxidising cladding (white, pitted and or powdery)		
The chimney <u>does not</u> display a manufactures information plaque?		
Damper installed? Do all pistons and brackets appear to be in place as viewed from ground?		
Any unusual noises coming from the chimney indicating possible internal failures i.e. excessive movement of internal flue risers etc.?		
Condition of the mating flange arrangements that can be viewed from ground. (flanges shall be examined when reached. No laddering past flange arrangements until each one has been checked).		
Do flange bolt centres appear to exceed 5x the diameter of the bolt installed on the flange or are over 150mm apart?		
If stiffening rings are fitted do they visually remain intact?		
<u>Notes: (any other areas of concern or worthy of note)</u>		

Completion of the above should provide suitable and sufficient evidence to either proceed with laddering and inspecting the chimney with caution or immediately identify concerns which could indicate the chimney may not have been designed to a recognised chimney build standard or the condition of the chimney does not lend itself to being laddered.

## Appendix 6 – Table for Recommended Frequency of Inspections

<b>Table 1 – Inspection Scheme for Unlined, Un-insulated Chimneys</b>
<p><b>Annually</b></p> <ul style="list-style-type: none"><li>• Clean out any flue deposits from base of stack whilst assuring compliance with COSHH regulations (can be completed by the chimney owner).</li><li>• Carry out close visual examination over the complete surface of the external face of the shell.</li><li>• Carry out ultra-sonic survey of chimney shell in sufficient detail to allow any significant loss of section to be detected.</li><li>• Tap all flange bolts &amp; holding down bolts with a hammer to 'sound' for any evidence of cracking.</li><li>• Check torque settings on flange and holding down bolts</li><li>• Examine any installed lightning protection system for compliance with current standards and carry out electrical tests for continuity and resistance to earth.</li></ul>
<p><b>4 Yearly</b></p> <ul style="list-style-type: none"><li>• All Annual items +</li><li>• Remove two bolts from each flange (or from most stressed flanges where adequate design drawings are available) for microscopic examination for defects. Bolts should then be tested for ultimate tensile failure for comparison against rated new bolts.</li></ul>
<p><b>8 Yearly</b></p> <ul style="list-style-type: none"><li>• All Annual and 4 yearly items +</li><li>• Carry out ultra-sonic survey on bolts securing stack to foundation to determine the extent of any corrosion present.</li></ul>

**Table 2 – Inspection Scheme for Externally Insulated Chimneys**

**Annually**

- Remove all accumulated deposits within base of stack whilst assuring compliance with COSHH regulations (can be completed by the chimney owner).
- Examine any installed lightning protection system for compliance with current standards and carry out electrical tests for continuity and resistance to earth.

**Biennially**

- All annual items +
- Carry out a detailed inspection of the insulation and cladding to determine its overall effectiveness and resistance to rainwater ingress.
- If internal access is possible, carry out a full inspection and take ultra-sonic measurements at sufficient locations to determine if any significant loss of section has occurred. (confined space regulations may apply).
- If internal access is not possible cut out apertures through the cladding and carry out ultra-sonic thickness survey. Locations to be selected to coincide with known vulnerable areas (above flange joints, insulation collars, base plates and duct entries) and also at random intervals throughout the height of the chimney. Thickness readings to be carefully plotted to match each inspection window for future comparison. Ensure that inspection apertures are adequately sealed against water ingress on completion of inspection.
- Remove flange cover boxes, where fitted, and inspect flange joints for leakage.
- Tap all flange bolts & holding down bolts with a hammer to 'sound' for any evidence of cracking.
- Check torque settings on flange and holding down bolts

**4 Yearly**

- All annual and biennial items +
- Remove two bolts from each flange (or from most stressed flanges where adequate design drawings are available) for microscopic examination for defects. Bolts should then be tested for ultimate tensile failure for comparison against rated new bolts.

**8 Yearly**

- All Annual, biennial and 4 yearly items +
- If internal access to the stack is not possible remove all external cladding and insulation to enable a detailed ultra-sonic thickness survey to be undertaken throughout the full height and circumference of the chimney.  
  
*Note: this procedure should also be considered if no design details are available and/or the stack has not been inspected to the required detail in accordance with the recommended time periods described in this document.*
- Carry out ultra-sonic survey on bolts securing stack to foundation to determine the extent of any corrosion present.



**Table 3 – Inspection Scheme for Lined Chimneys**

**Annually**

- Examine any installed lightning protection system for compliance with current standards and carry out electrical tests for continuity and resistance to earth.

**Biennially**

- All annual items +
- Carry out a detailed survey of the shell including for the ultra-sonic thickness measurement at sufficient locations to determine any areas of significant loss of section.
- If internal access is possible, carry out a full inspection to determine the overall condition of the lining system (confined space and COSHH regulations may apply).
- If internal access is not possible consideration should be given to carrying out an internal inspection using a remote camera system.
- Any defective areas noted within the lining system should result in a particularly detailed examination of the shell in this area.
- Defects within the lining system exposing the shell to flue gases should be rectified prior to returning the stack to service.
- Tap all flange bolts & holding down bolts with a hammer to 'sound' for any evidence of cracking.
- Check torque settings on flange and holding down bolts

**4 Yearly**

- All annual and biennial items +
- Remove two bolts from each flange (or from most stressed flanges where adequate design drawings are available) for microscopic examination for defects. Bolts should then be tested for ultimate tensile failure for comparison against rated new bolts.

**8 Yearly**

- All Annual, biennial and 4 yearly items +
- Carry out ultra-sonic survey on bolts securing stack to foundation to determine the extent of any corrosion present.

*The above tables have been extracted from the ATLAS guidance document 'Guide to the Inspection of Single Flue Industrial Steel Chimneys' published in February 2004.*

## Appendix 7 – High Risk Chimneys

Chimneys can be attacked both externally and internally.

**B1 external attack** of which corrosion is the main form, is caused by acids. These acids are formed when pollutants containing acid gases dissolve in atmospheric moisture; they are deposited onto the chimney either as condensation or rain. But the process is slow and not one which should cause concern, especially with insulated chimneys. However, in highly contaminated atmospheres, uninsulated chimneys may be at risk.

*Guidance about which are high risk environments is given in table 4 below.*

**B2 internal attack** is of a major concern, because it is not immediately apparent. It can cause rapid deterioration if it is not detected. There are two main causes, as follows:

**Corrosion** is the most common form. Sulphuric acid, formed out of the condensates of fuels containing sulphur, is the most corrosive agent. Generally, the higher the sulphur content of the fuel the greater the chance of sulphuric acid condensing out inside the steel chimney.

*The sulphur content of some commonly incinerated products is given in table 5 below.*

To initiate corrosion the acids must be in solution, i.e. the temperature at the surface of the steel chimney must be below the acid dew point. For sulphuric acid, this is between 120°C and 160 °C, depending on the sulphur content. If the heat source which the chimney is venting is switched off regularly, the temperature within the chimney will, unavoidably, fall below dew point temperature, allowing the acid to condense out on the inside surface of the steel chimney. As long as the chimneys exposure to acid attack is limited, the fact that the temperature is below the acid dew point need not be serious.

*Table 6 below relates off-load periods to susceptibility to acid attack.*

**Abrasion** can also cause rapid deterioration, but it is limited to chimneys burning solid fuels and usually at positions where the flow in a chimney changes direction. But beware; if it acts in combination with corrosion, it can cause an even more rapid loss of section.

Environment Category	Environment	Description of environment	Steel Corrosion Risk
A	Normal Inland	Most rural and urban areas. (Note: Some rural and urban areas may be polluted from industrial areas close by, depending on prevailing winds).	Low
B	Polluted Inland	Area with high airborne SO <sub>2</sub> and other contaminants from industrial sources.	Significant
C	Normal Costal	High airborne salt (Cl) levels. (The salt contaminated zone may extend inland as far as 2-3km from the coast).	High
D	Polluted Costal	As with B but with high airborne salt levels. (The contaminated zone may extend inland as far as 2-3km from the coast).	Very High
E	Heavily Polluted Industrial	Aggressive industrial environments such as areas adjacent to acid plants, salt storage, electroplating shops, chemical works, etc.	Very High

**Table 4:** Information about environments for external attack.

Sulphur Content	Classification of risk to chimney in terms of fuel sulphur content	Examples
0% to 0.3%	Low	Natural Gases, domestic refuse
0.4% to 1.5%	Medium	Diesel
Greater than 1.6%	High	Industrial coal, heavy oil.

**Table 5:** Classification of commonly incinerated products by sulphur contents.

Operating hours per year below acid dew point	Risk of corrosion
<30 hours	Low
30-100 hours	Medium
>100 hours	High

**Table 6:** relating time below acid dew point to risk of corrosion

\* Chimneys should be maintained at 20 °C above the acid dew point.

*The above tables have been extracted from the ATLAS guidance document ‘Guide to the Inspection of Single Flue Industrial Steel Chimneys’ published in February 2004.*

## Appendix 8 – New Technologies – UAV or Drones

### Applications

The use of **Un-Manned Aviation Vehicles (UAV)** or Drones is becoming increasingly popular in the commercial environment. Their ability, in some cases to remove an initial requirement to expose operatives to working at height, cannot be ignored.

The overall effectiveness of using a drone to help establish and confirm the structural condition of a steel chimney is currently very limited. However, as technologic advances continue the ability of a UAV fitted with an attachment such as a heat camera potentially offer real benefits, particularly in identifying any problems with an internal chimney lining, whilst the chimney remains in service.

In other possible scenario’s, a UAV could initially be deployed to survey the summit of a tall structure to establish if there are any potential structural issues that could be encountered during the inspection, all prior to an inspection taking place. This could include identifying any loose or damaged components at the chimney summit such as a failed capping arrangement which otherwise may not be visible from ground level and could represent a hazard to the operatives carrying out a tactile inspection or work to the chimney.

In this scenario this would allow the work to be fully strategised to meet such challenges that otherwise couldn’t have been established at planning stage.

### Using a UAV or Drone

In the UK the use of a UAV is strictly governed. Any company wishing to use a UAV must first obtain a commercial operator’s license. The operator of the UAV (Pilot) must be suitably qualified. As a minimum this will see the pilot trained and certificated in accordance with the requirements of the Civil Aviation Authority (CAA).

As with any commercial undertaking the use of a UAV must be covered by a suitable insurance policy.

An operation or flight procedure for a UAV must be in place, this procedure must be robust and include preparatory undertakings all prior to flying which will include but not be limited to notifying local airports and RAF bases of the intention to fly a UAV. This will usually see providing coordinates of the site/area and confirming the maximum altitude that the UAV will be able to operate within an agreed flying zone to ensure it possess no threat to air traffic.

In addition, the flight procedure should include a spotter for the pilot, the role of the spotter will be to keep the UAV in sight at all times during the flight and in so doing ensure the UAV does not exit beyond the established and permitted flight zone.

**Note:** ATLAS acknowledge that the use of a UAV has the potential to capture and record footage that could be commercially sensitive. ATLAS would therefore always advise that such potential issues are considered and appropriate measures applied at planning stage to remove or reduce any potential for such commercial or security breaches.

## Appendix 9 – Training and Competence for Access Specialist Workers

- 1) Work at height is potentially dangerous and those involved in work at height need appropriate knowledge, skills and experience to carry out specialist access work safely and competently. A competent access specialist will be one who has:
  - a. has sufficient knowledge to undertake the task safely, and to recognize his limitations;
  - b. understands any potential hazards related to carrying out the work and the use of the equipment; and
  - c. can detect technical defects or omissions in that work (or equipment), recognize any implications for health and safety caused by those defects or omissions, and be able to take appropriate action to prevent harm.
- 2) Trainees or less experienced height workers need to be under the supervision of a competent person.
- 3) If you control the work of persons operating at height, you shall have clear procedures that identify those tasks or work activities which require specific competences, and authorise only competent workers to carry them out.
- 4) Developing competence in health and safety is an ongoing process. Individuals will develop their competence through experience in the job and through training, which is part of 'lifelong learning'
- 5) Passing the basic Construction Skills Health and Safety Test, or an equivalent, provides evidence of a threshold of health and safety knowledge appropriate for a new starter in construction. Whether CSCS or equivalent, the correct category of card or certification should be held for the type of work to be carried out. Cards applicable to the work carried out in this guide include;
  - a. Steeplejack Industry Accreditation A
  - b. Steeplejack Assessed Route B
  - c. Steeplejack Brick/Concrete Structures
  - d. Steeplejack Church/Stone Steeplejack Steel Structures
  - e. L.C. Engineer Industry Accreditation A
  - f. L.C. Engineer Assessed Route B

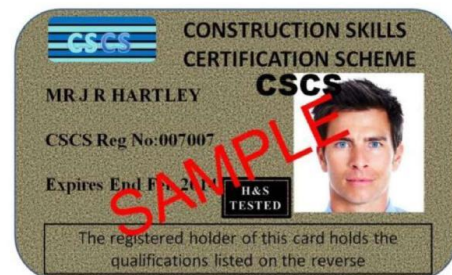

- 6) To achieve competence, workers should be trained in safe working practices and those health and safety issues specific to their trade. It is not enough to hope that they will 'pick up' safety on the job from other workers - they might simply be learning someone else's bad habits. Employers need to be sure of their employee's abilities before setting them to work and must provide training where it is required. Access specialists will need training on the risks they will encounter (such as understanding fall protection) and safe systems of work to control them.
- 7) British Standard BS 8454:2006 provides guidance and recommendations on the delivery of training and education for work at height, including rescue.